

Frosty Factory

Model 113



- **Compact Size -**
Saving valuable counter space
- **3 1/2 Quart Cylinder**
8 quart hopper
- **Production -**
Up to 64 ten ounce drinks
- **Stand-by-Switch -**
Refrigerates mix overnight
- **Air Cooled -**
Simple Install

Frosty Factory of America

2301 S. Farmerville St., Ruston, LA 71270

www.frostyfactory.com

(318) 255-1162 ■ (800) 544-4071 ■ (318) 255-1170 FAX

Frosty Factory Model 113

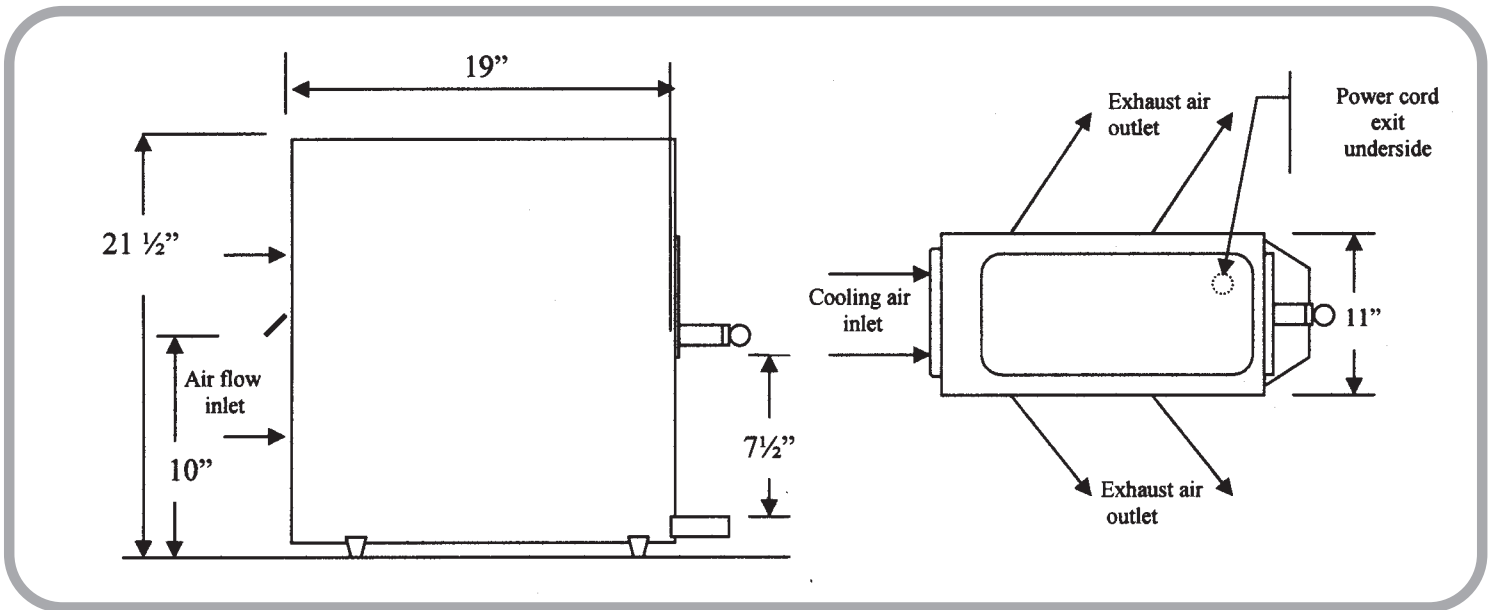

Specifications

- Height: 21 1/2 in. -- 55 cm.
- Width: 11 in. -- 28 cm.
- Depth: 19 in. -- 48 cm.
- Weight: 90 lbs. -- 41 kg.
- Legs: 1 in. -- 2 1/2 cm.
Optional: 4 in. -- 10 cm
- Shipping Size: 15"W X 25"D X 31"H
38 cm.W X 64 cm.D X 79 cm.H
- Shipping Volume: 7 cu. ft. -- 1/5 cu.M.
- Shipping Weight: 100 lbs. -- 45 kg.
- Voltage: 115 -- Opt. 230
- Hertz: 60 -- Opt. 50
- Phase: 1
- Cooling: Air
- Air Clearance: 8 in. -- 20 cm (All Sides)
- Hopper Capacity: 8 qts. -- 7 1/2 ltr.
- Cylinder Capacity: 3 1/2 qts. -- 3 1/4 ltr.
- Amperage Draw: 10 amps
- Circuit Breaker: 20 amp
- Compressor: 1/3 h.p.
- Refrigerant: R404A



Due to continuous research specifications subject to change without notice.

Frosty Factory of America

2301 S. Farmerville St., Ruston, LA 71270

www.frostyfactory.com

(318) 255-1162 ■ (800) 544-4071 ■ (318) 255-1170 FAX_{10/08}